

**The Director of the United States
Patent and Trademark Office**

The
United
States
of
America

Has received an application for a patent for a new and useful invention. The title and description of the invention are enclosed. The requirements of law have been complied with, and it has been determined that a patent on the invention shall be granted under the law.

Therefore, this

United States Patent

Grants to the person(s) having title to this patent the right to exclude others from making, using, offering for sale, or selling the invention throughout the United States of America or importing the invention into the United States of America, and if the invention is a process, of the right to exclude others from using, offering for sale or selling throughout the United States of America, or importing into the United States of America, products made by that process, for the term set forth in 35 U.S.C. 154(a)(2) or (c)(1), subject to the payment of maintenance fees as provided by 35 U.S.C. 41(b). See the Maintenance Fee Notice on the inside of the cover.



Leea Staret Lee

Acting Director of the United States Patent and Trademark Office



US00D694670S

(12) **United States Design Patent**
Oren

(10) **Patent No.:** **US D694,670 S**
(45) **Date of Patent:** **** Dec. 3, 2013**

(54) **TRAILER FOR PROPPANT CONTAINERS**

(71) Applicant: **Joshua Oren**, Houston, TX (US)

(72) Inventor: **Joshua Oren**, Houston, TX (US)

(**) Term: **14 Years**

(21) Appl. No.: **29/455,210**

(22) Filed: **May 17, 2013**

(51) **LOC (9) Cl.** **12-10**

(52) **U.S. Cl.**
USPC **D12/101**

(58) **Field of Classification Search**
USPC D12/100-106, 19, 129, 111-112;
D21/425, 435; D34/21-26, 12, 16-19;
280/204, 205, 63, 475, 482, 647;
296/168, 180, 180.2, 61, 10,
296/100.01-100.08
See application file for complete search history.

(56) **References Cited**

U.S. PATENT DOCUMENTS

D199,118 S * 9/1964 McKillop D12/103
3,185,519 A * 5/1965 Turnbull et al. 296/184.1
5,201,546 A * 4/1993 Lindsay 280/789

5,351,990 A * 10/1994 Thomas 280/789
D402,233 S * 12/1998 Warlick D12/101
D417,172 S * 11/1999 Smith et al. D12/101
6,932,388 B2 * 8/2005 Few et al. 280/787
D558,097 S * 12/2007 Winter et al. D12/101
D648,656 S * 11/2011 Crane D12/101

* cited by examiner

Primary Examiner — Katrina A Betton

(74) *Attorney, Agent, or Firm* — Egbert Law Offices, PLLC

(57) **CLAIM**

The ornamental design for a trailer for proppant containers, as shown and described.

DESCRIPTION

FIG. 1 is an upper perspective view of the trailer for proppant containers showing my new design.
FIG. 2 is a side elevation view thereof;
FIG. 3 is an opposite side elevation view thereof;
FIG. 4 is a front elevation view thereof;
FIG. 5 is a rear elevation view thereof;
FIG. 6 is a top plan view thereof; and,
FIG. 7 is a bottom plan view thereof.
The features presented in broken lines are for environmental purposes only and form no part of the claimed design.

1 Claim, 3 Drawing Sheets

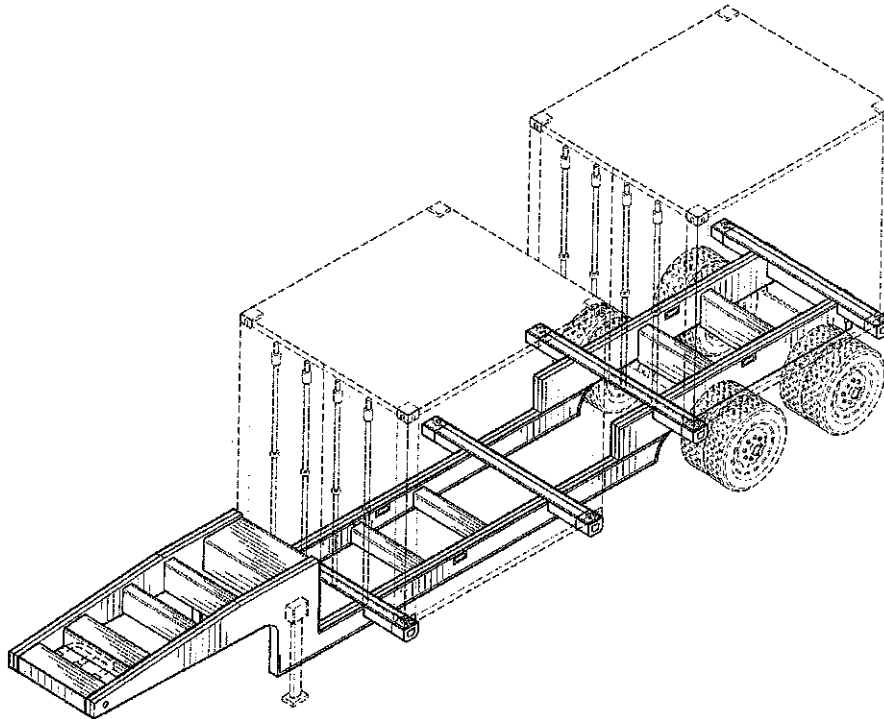

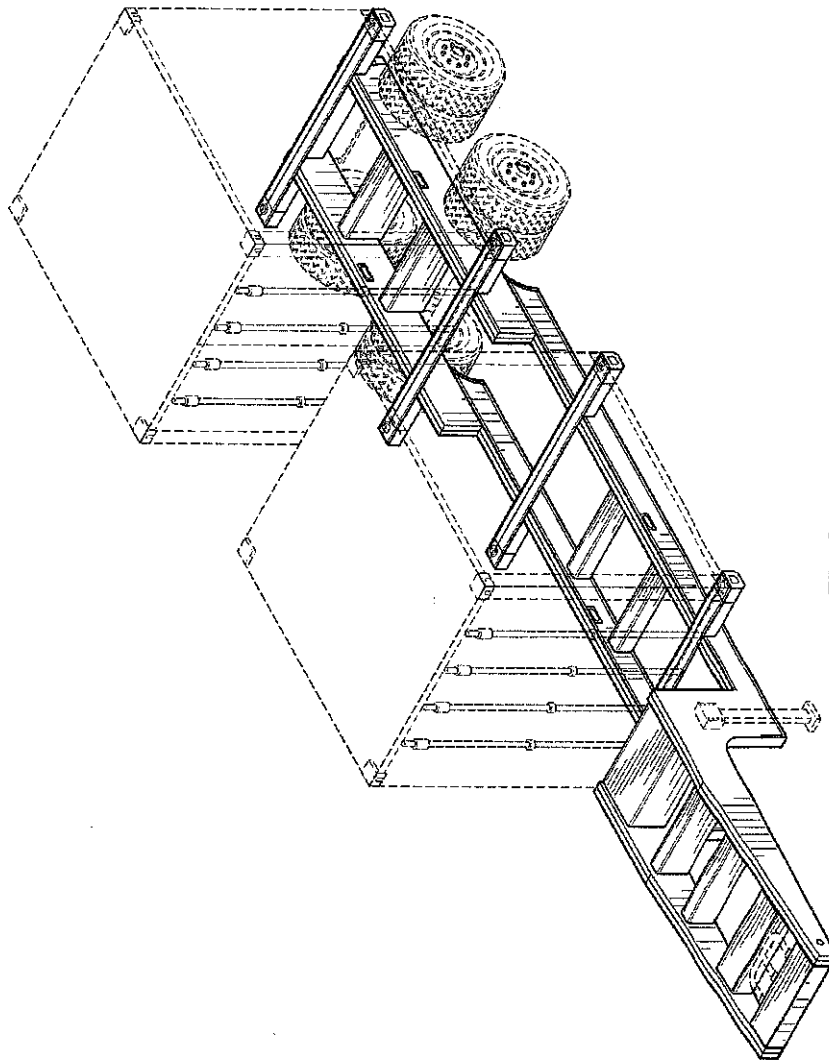

FIG. 1

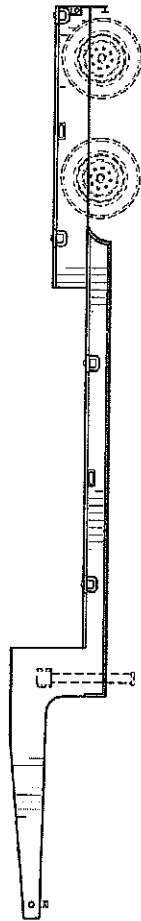

FIG. 2

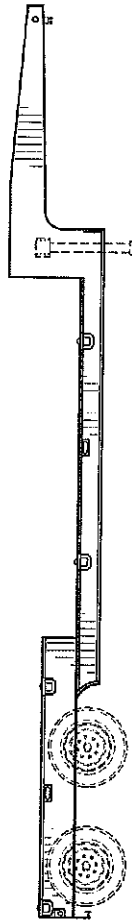

FIG. 3

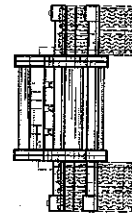

FIG. 4

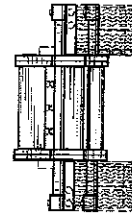

FIG. 5

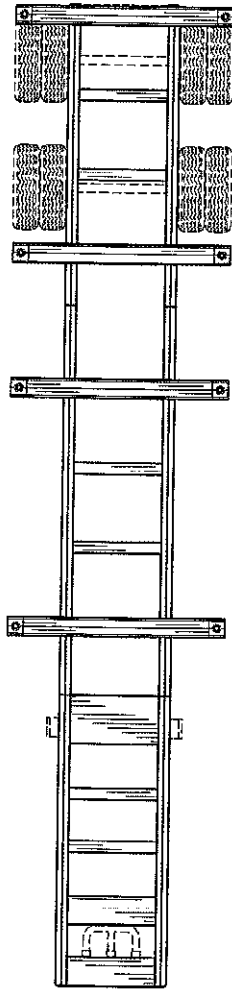

FIG. 6

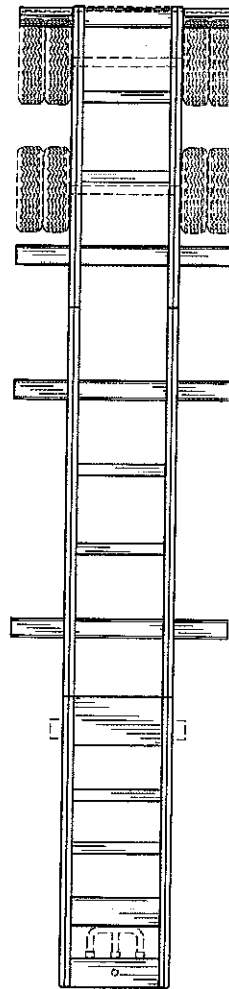

FIG. 7